

Cost Effective Solutions for Pick and Place

NARESH KANTOR
CEO,
Encon Systems International, Gurgaon

Dec 2011, New Delhi

Encon Systems

**461, Pace City II, Sector 37,
Gurgaon – 122001, Haryana, India.**

Tel. 91-124-4276461 to 4276463

Fax. 91-124-4276460

e-mail :- etpl@enconsystems.com

website :- <http://www.enconsystems.com>

EnconSystems

Encon Systems

Channel Partners

Rockwell
Automation

**

***IAI* - Intelligent Actuators, Japan**
Cartesian & SCARA Robots.

EnconSystems

WHAT DO WE DO ?

- **Manufacturing Automation**
- **Pick and Place Systems**
- **Transfer Systems**
- **Robotics**
- **End of Line Automation**
- **Manufacturing Intelligence**

IN THIS PRESENTATION WE WILL COVER -

- 1. Type of Pick and Place Systems**
- 2. Considerations for Choosing Pick and Place**
 - 1. Technologies for Pick and Place**
 - 2. Case Studies**

Type of Pick and Place Systems

- **Mechanical systems**
- **Pneumatic Systems**
- **Electrical Actuators**
- **Robots**

Considerations for Choosing Pick and Place Systems

- **Cycle Time of operation**
- **Accessibility Options**
- **Space Constrains**
- **Component shape**
- **Environment**
- **Safety considerations**

Technologies for Pick and Place Systems

- **Linear Movements**
 - End to End Positioning
 - Multi-positioning
- **Rotary Actuators**
- **Gripping Systems**
- **Multiple component handling**



slitting.swf



XY Tube filling.swf

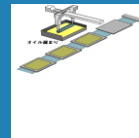

EnconSystems

Cartesian Pick and Place

- **Linear Axis Mounted on each other**
 - **No rotary movement**
 - **End to end or multi position**
 - **Single axis or multi axis**
- **Can be built with pneumatic or servo axis**



EnconSystems

Multi Axis Cartesian Pick and Place

Example - Linear Slides mounted on each other to form X-Y-Z three axis system.

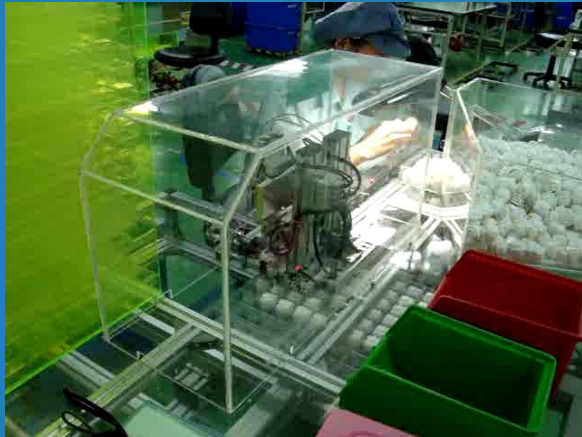

EnconSystems

Examples 3 axis Application

**3-Axis Cartesian for
Cream Dispensing**



**3-axis Application
for Part feeding**



EnconSystems

SCARA Pick N Place

- Combination of Linear and Rotary Axis
- Can be used for very high speed application
- Can be expensive



EnconSystems

Coordinated Handling with Pick and Place

EXAMPLE

- Coordinated Conveyors,
- Servo Systems
- Linear Slides
- Gripper
- Transfer

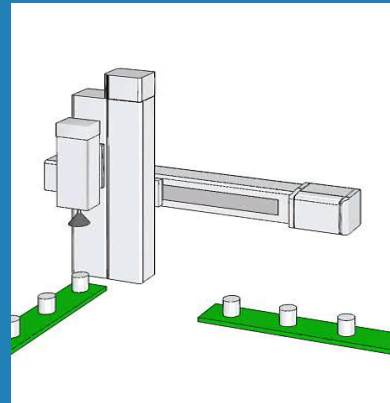

Case Study

EXAMPLE 1 – Palletizing Gantry

Heavy Part,
Difficult to handle manually
Operator fatigue



EXAMPLE -2 Palletizing - Robot

Flexible Packaging
Multiple products
Programmable



EnconSystems

QUESTIONS ?

EnconSystems