



SINCE 1867

*WELCOME  
TO  
PRESENTATION  
ON  
EVOLUTION OF 200/210 LITRE STEEL  
BARRELS  
OVER THE YEARS IN  
INDIA*

# *THE PRODUCT*



**FOR THE SAFE  
CONTAINMENT  
OF  
LIQUID AND SOLID PRODUCTS  
INCLUDING  
HAZARDOUS PRODUCTS  
COMPLYING WITH  
THE INTERNATIONAL MARITIME DANGEROUS GOODS CONVENTION  
(UN)  
DURING  
STORAGE AND TRANSPORTATION OF THESE PRODUCTS**



BALMER LAWRIE & CO. LTD.  
TECHNOLOGY & PRODUCT DEV.  
(INDUSTRIAL PACKAGING DIV.)  
CALCUTTA

20G 200 LTRS. TIGHT HEAD  
STEEL BARREL

DRAWING NO.  
SHT.-014

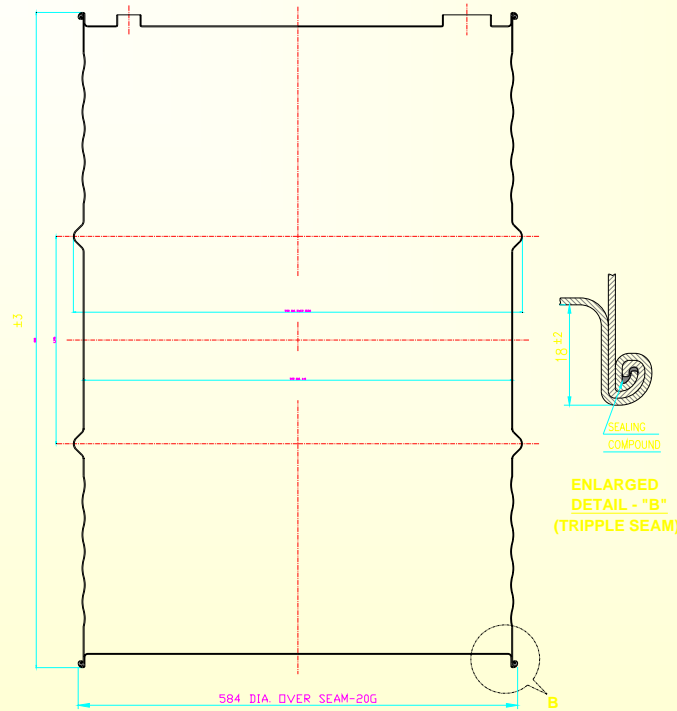

DRAWN BY

SHT. OF

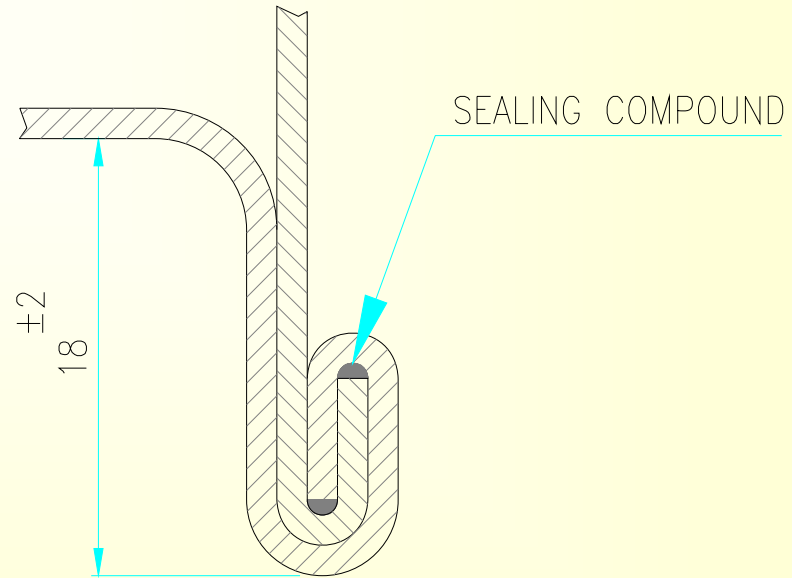

DOUBLE SEAM

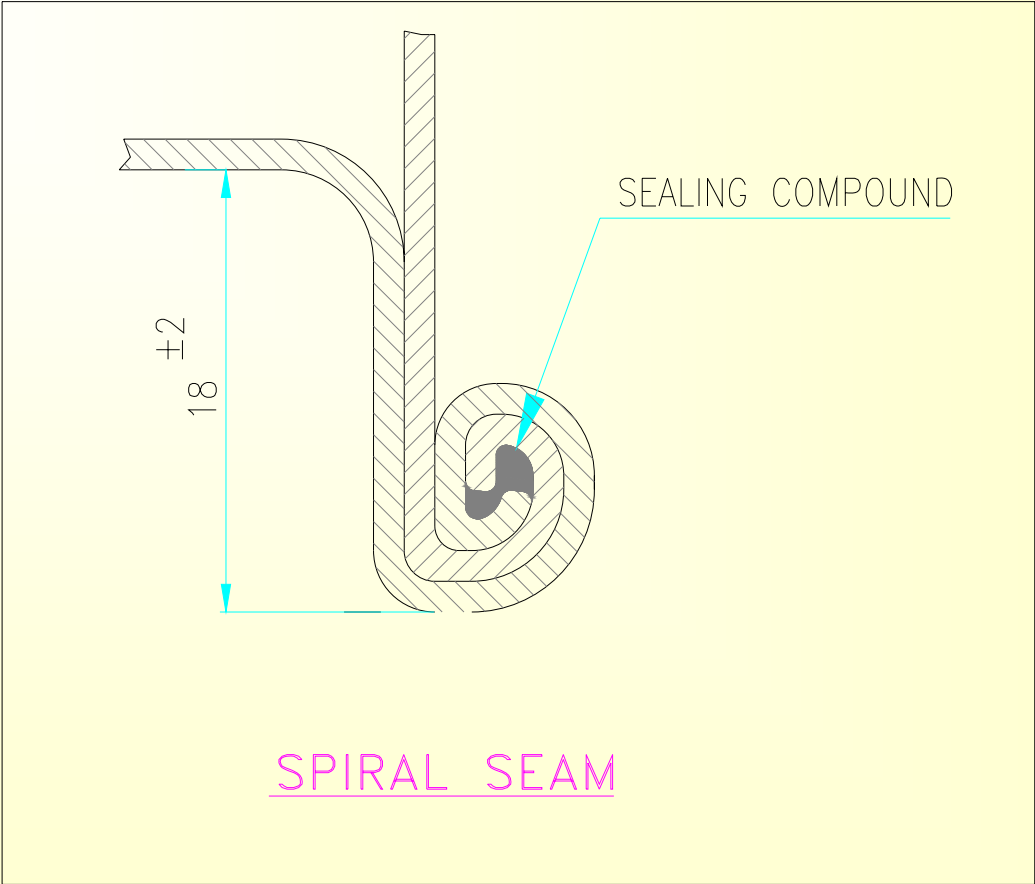

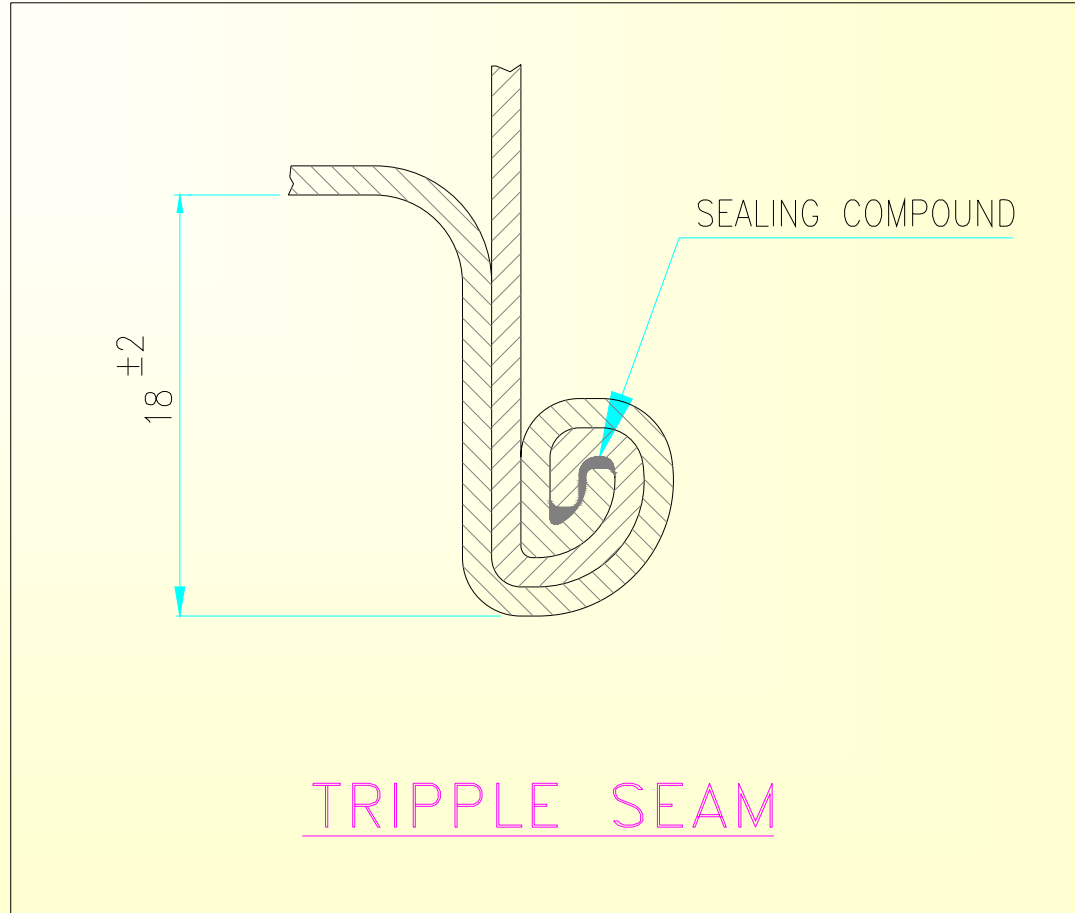

TRIPPLE SEAM

## *1950's TO 1960's*

- **HANDFUL OF 3-5 BARREL MANUFACTURERS IN WEST/EAST**
- **RELIANCE ON IMPORTED STEEL**
- **RELIANCE ON IMPORTED CLOSURES (ONLY 1 MANUFACTURER IN INDIA)**
- **COMPLETELY MANUAL MANUFACTURING OPERATIONS – HAND MADE BARRELS**
- **LUBRICANT OILS - ONLY CUSTOMER SEGMENT**
- **PRODUCT RANGE LIMITED TO TIGHT HEAD AND OPEN HEAD BARRELS**

## *1970's TO 1991(PRE-LIBERALISATION)*

- **BARREL MANUFACTURERS GROW TO 8 IN NUMBERS INCLUDING IN SOUTH/NORTH**
- **BOKARO STEEL PLANT LARGEST SUPPLIER OF CR STEEL TO THE INDUSTRY**
- **ADDITIONAL CLOSURE MANUFACTURERS START OPERATIONS**
- **SEMI-AUTOMATION IN MANUFACTURING OPERATIONS**
- **PETROCHEMICALS, TRANSFORMER OILS, OTHER CHEMICALS EXPAND THE CUSTOMER SEGMENTS FOR STEEL BARRELS**
- **PRODUCT RANGE EXPANDS TO TIGHT HEAD, OPEN HEAD, LACQUERED AND GALVANISED BARRELS**

# *INDUSTRY STRUCTURE DEMAND (MILLION)*

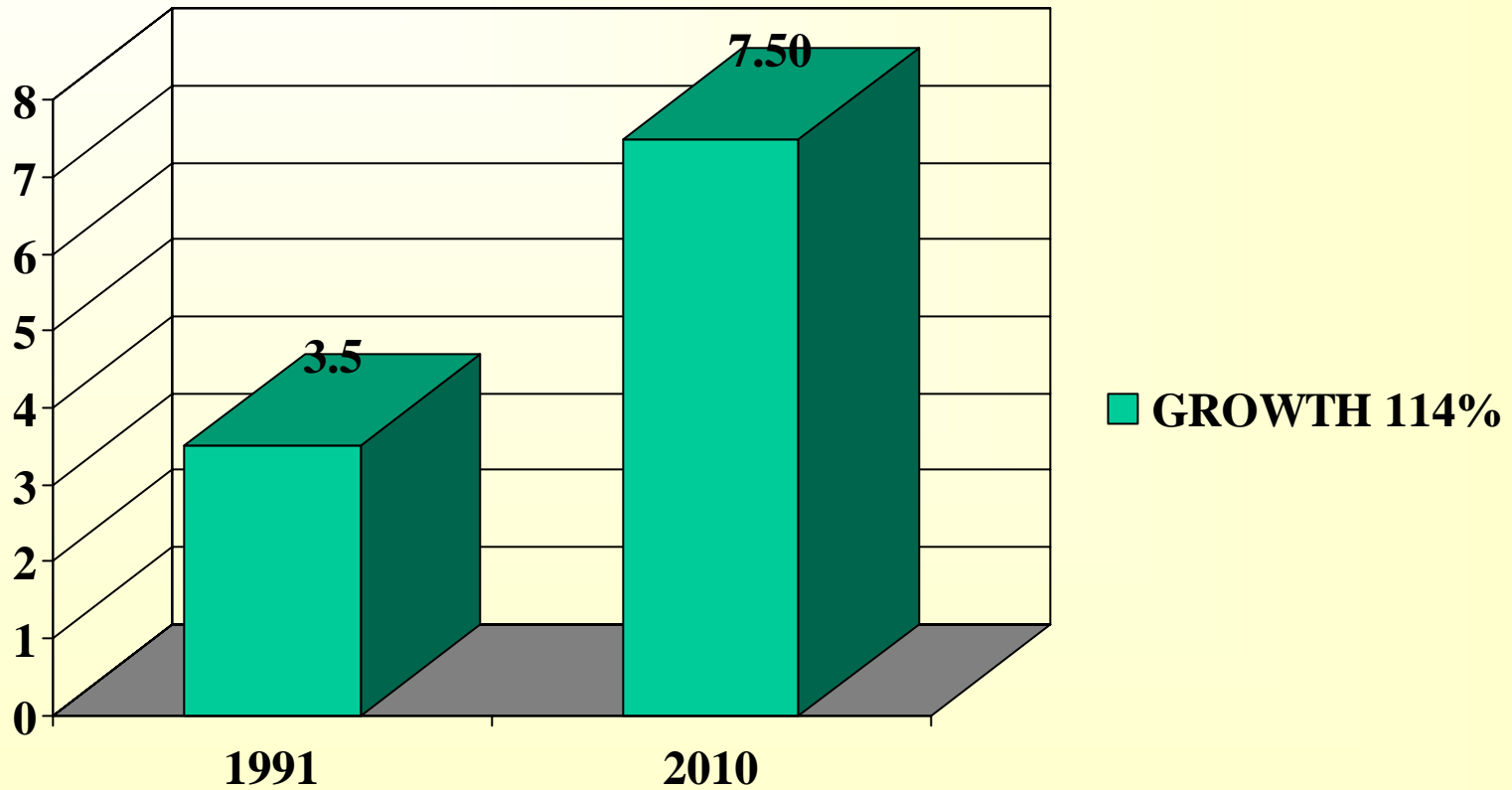

# *INDUSTRY STRUCTURE*

## *STEEL DRUM MANUFACTURERS*

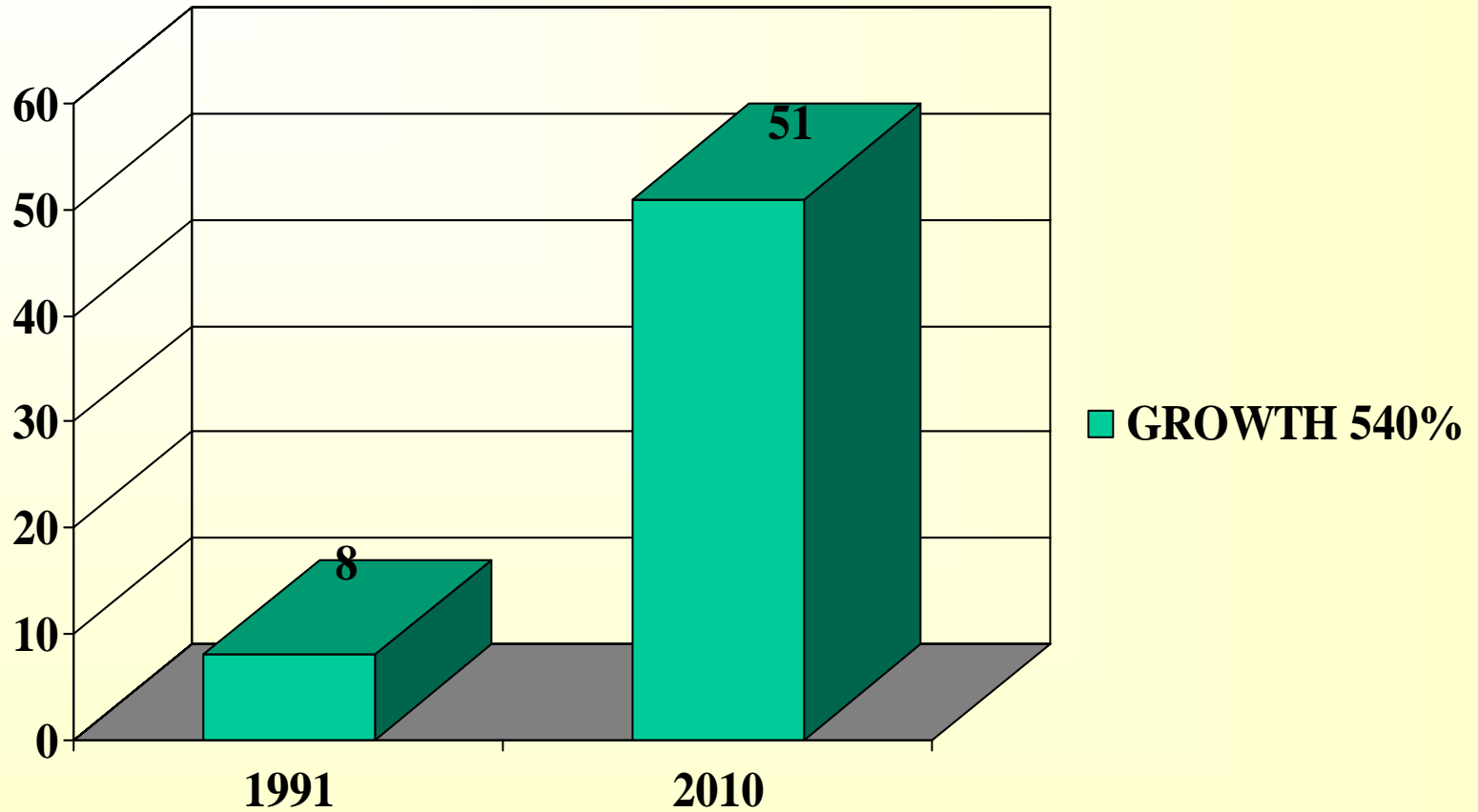

# *INDUSTRY STRUCTURE*

## *MANUFACTURING CAPACITY (MILLION)*

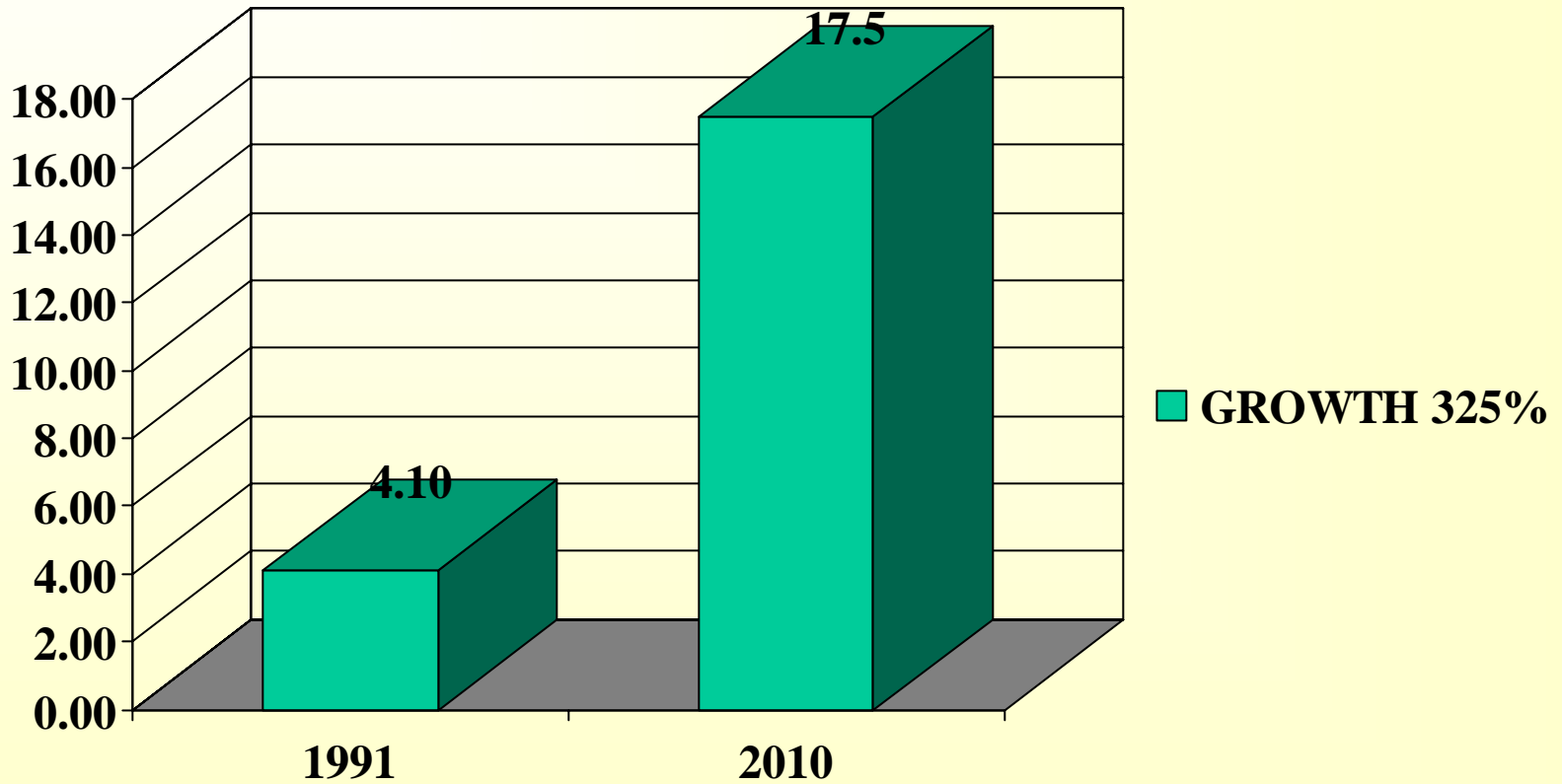

# *INDUSTRY STRUCTURE EXCESS CAPACITY (MILLION)*

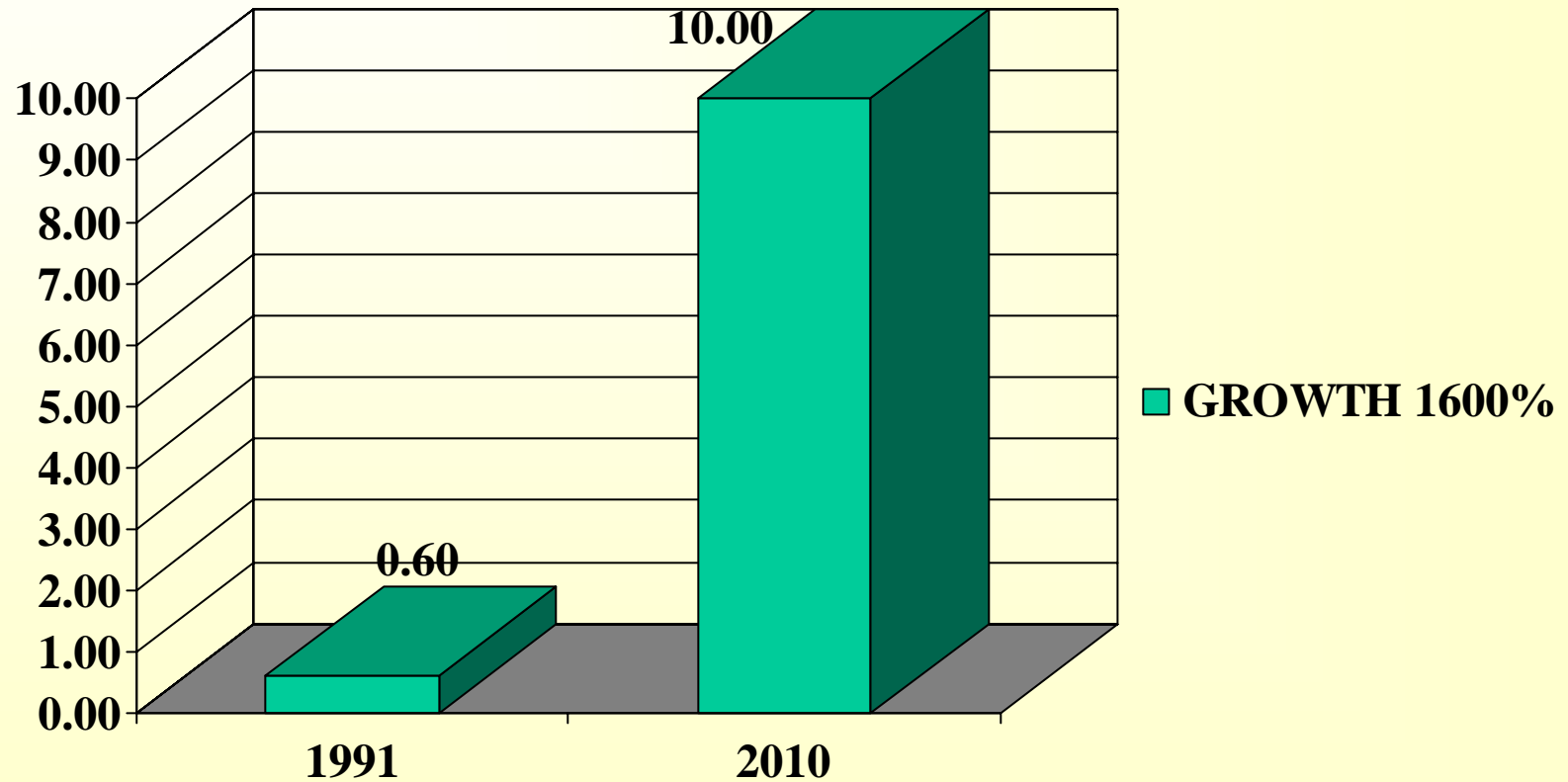

# INDUSTRY STRUCTURE CUSTOMER NUMBERS

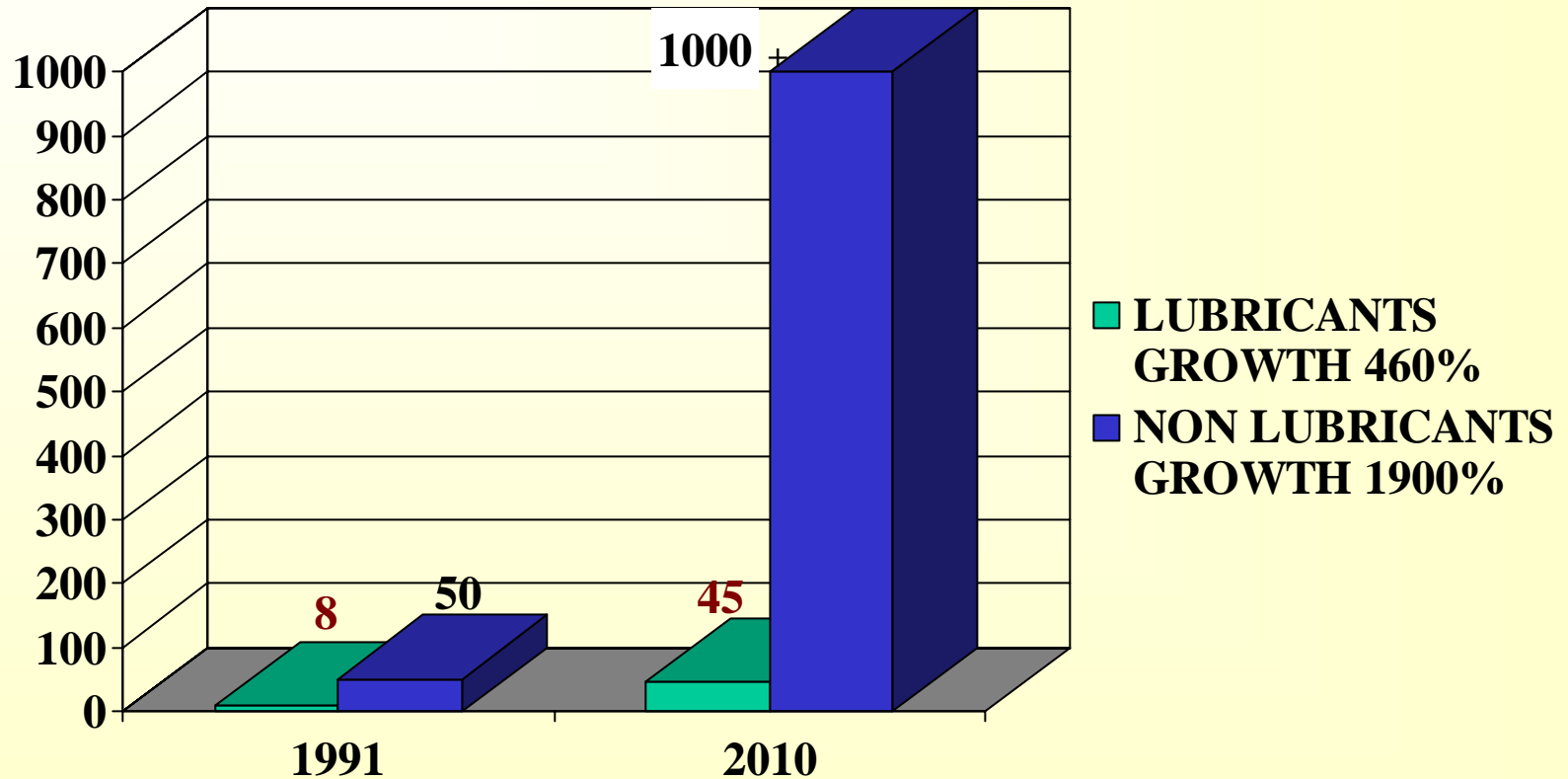

# INDUSTRY STRUCTURE INTEGRATED STEEL MILLS

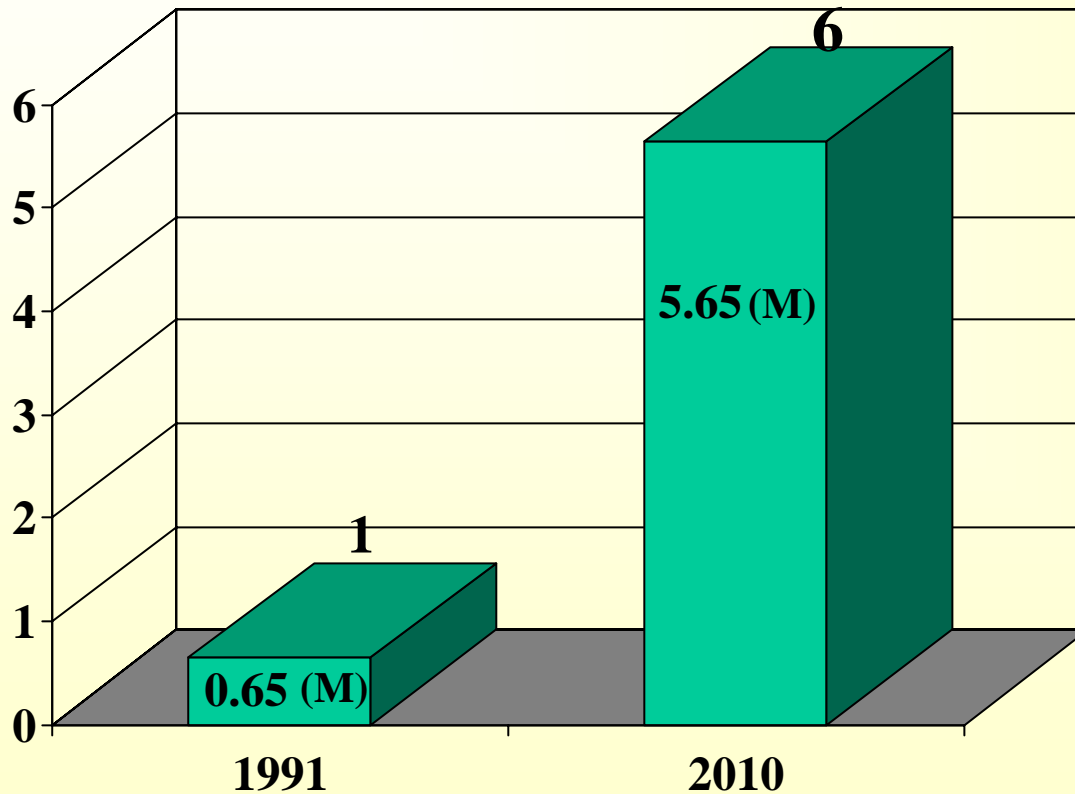

■ GROWTH 40% IN NO'S  
770 % IN CAPACITY

**RE-ROLLERS IMPORTS**

- POSCO
- ARCELOR – MITTAL
- JFE
- SUMITOMO
- EXISTING MILLS

# INDUSTRY STRUCTURE CONSUMER SEGMENTS

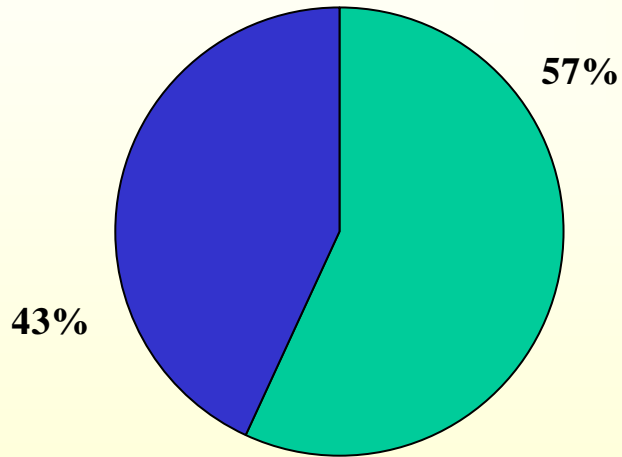

■ LUBRICANTS  
■ NON LUBRICANTS

**2000**

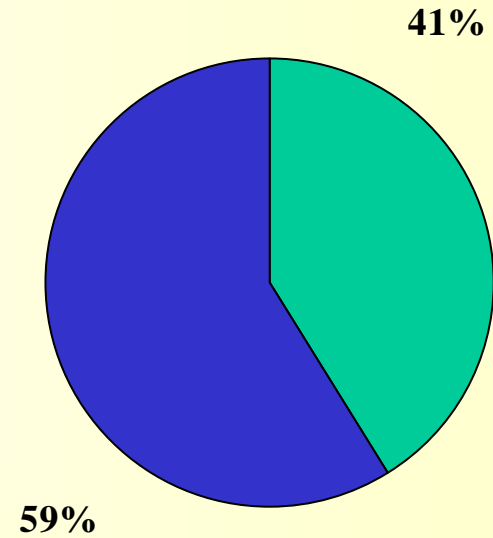

■ LUBRICANTS  
■ NON LUBRICANTS

**2010**

# *INDUSTRY STRUCTURE CONSUMER SEGMENTS*

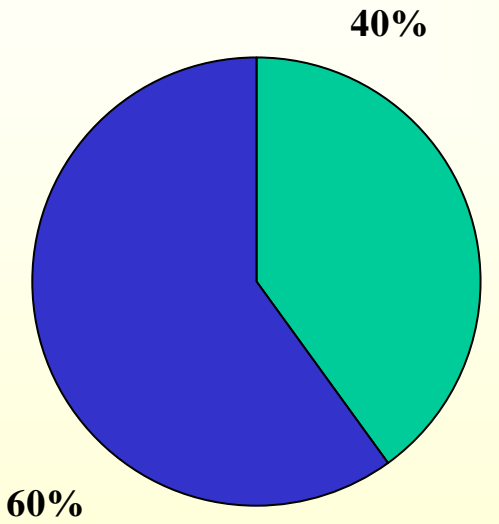

■ GOVT SECTOR  
■ PRIVATE SECTOR

**2000**

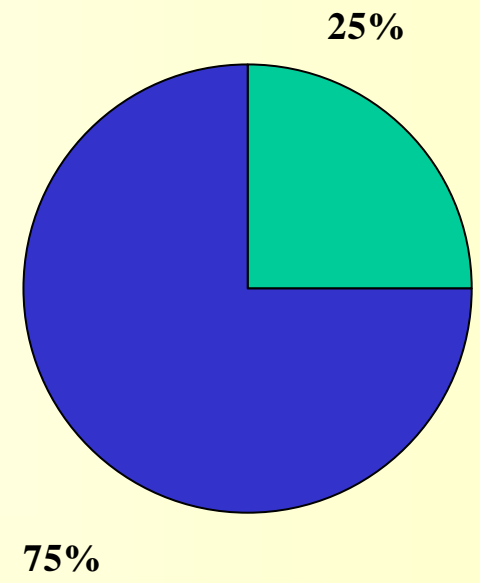

■ GOVT SECTOR  
■ PRIVATE SECTOR

**2010**

# PRODUCTWISE BREAKUP OF 200L NEW STEEL BARRELS

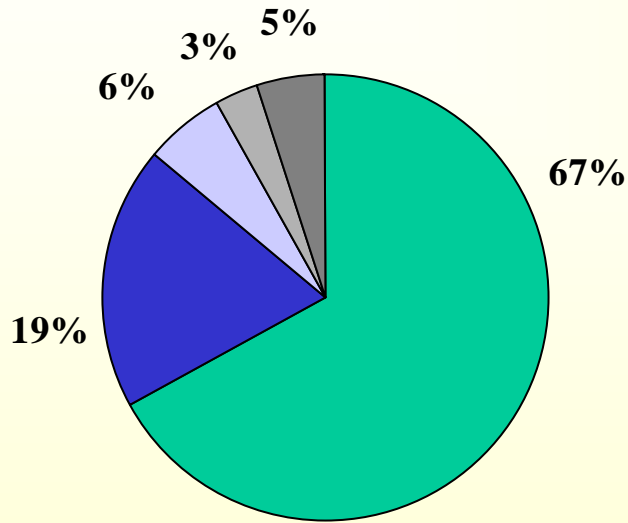

- PLAIN
- LACQUERED
- COMPOSITE
- GALVANISED
- OH INTERNALLY COATED

2000

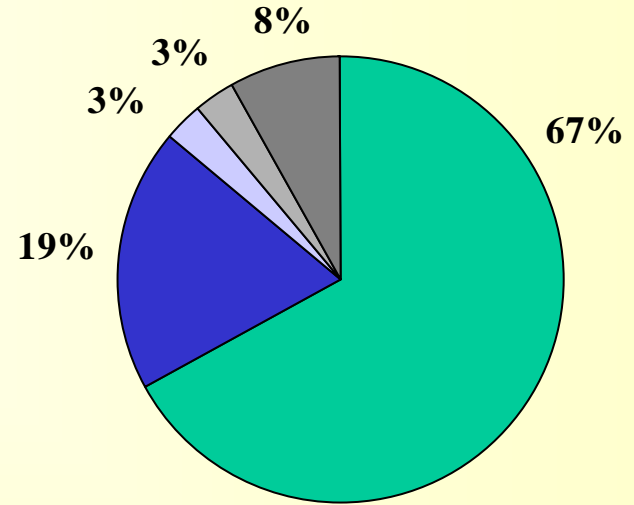

- PLAIN
- LACQUERED
- COMPOSITE
- GALVANISED
- OH INTERNALLY COATED

2010

# INDUSTRY STRUCTURE REGIONWISE DEMAND

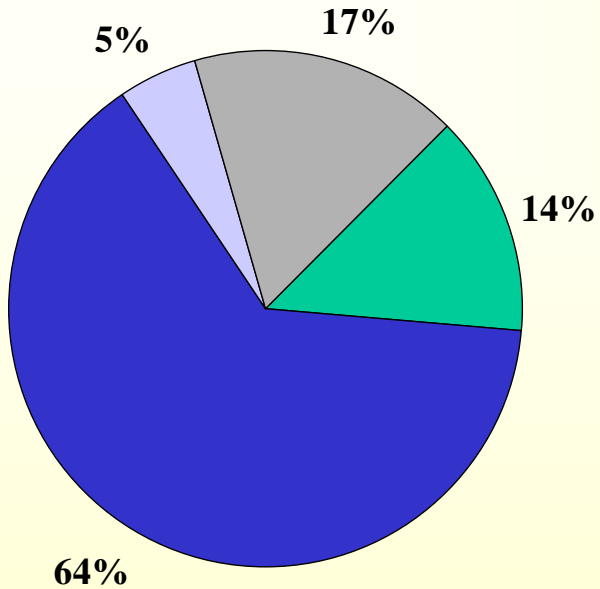

■ East ■ West ■ North ■ South

**2000**

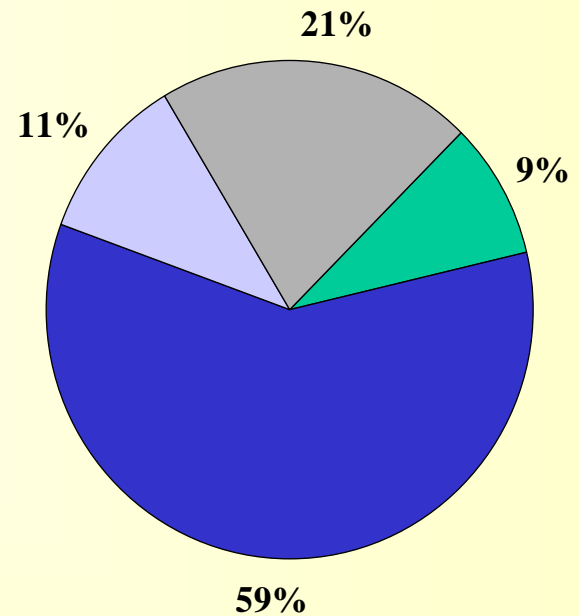

■ East ■ West ■ North ■ South

**2010**

# RAW MATERIALS

1991

## **STEEL**

OILED WITH CARBON SOOT  
LOW CONTROL ON THICKNESS  
1.25 MM  
MM

## **PAINT**

AIR DRYING  
QUALITY/

## **CLOSURES**

GLOBAL QUALITY

2010

DOS-A ECL

+/- 0.02 MM

1.00 MM, 0.90MM,0.80

PURE STOVING

WATER BASED PAINTS

GLOBAL QUALITY

# *TECHNOLOGY*

DOUBLE SEAM

TO

ROUND SEAM

HANDMADE

TO

FULLY AUTOMATED

1.25 MM

TO

1.00 MM OR LOWER

NO PRINTING

TO

2 COLOUR PRINTING

50-100 BARRELS/  
HOUR

TO

450 BARRELS/HOUR  
900 BARRELS/HOUR

# *CUSTOMER EXPECTATIONS*

NO LEAK

INTERNALLY SPOTLESS/CLEAN

EXTERNALLY SCRATCH PROOF PAINTING

WEATHER RESISTANT PRINTING

# *CURRENT ISSUES*

- **2008/09 FINANCIAL CRISIS HITS INDUSTRY HARD**
- **2009/10 SMART RECOVERY IN DEMAND**
- **RAPIDLY INCREASING STEEL PRICES**
- **70% OF COSTS**
- **HUGE EXCESS CAPACITY – SELECTIVE PRICE ATTRITION IN SOME SEGMENTS**
- **CUSTOMER SEGMENTS IN COMPETITIVE MODE**
- **REDUCED MARGINS**
- **THREAT FROM ALTERNATIVE PACKS – PLASTICS/FIBC/IBC/BULK**
- **UNHEALTHY FINANCIAL STATUS OF INDUSTRY**

## *POINTS TO PONDER*

-BIODEGRADABLE ECO GREEN PRODUCT

-CHALLENGES PRODUCT LIFE CYCLE THEORY ?

TRIBUTE



*Thank You*